

User Manual

Low Voltage Battery

MBL050/120/160



All Rights Reserved

All Rights Reserved

No part of this document can be reproduced in any form or by any means without the prior written permission of Sungrow Power Supply Co., Ltd (hereinafter "SUNGROW").

Trademark

SUNGROW and other Sungrow trademarks used in this manual are owned by SUNGROW. All other trademarks or registered trademarks mentioned in this manual are owned by their respective owners.

Software Licenses

- It is prohibited to use data contained in firmware or software developed by SUNGROW, in part or in full, for commercial purposes by any means.
- It is prohibited to perform reverse engineering, cracking, or any other operations that compromise the original program design of the software developed by SUNGROW.

About This Manual

This manual provides product information and guidance on the installation, operation, and maintenance of the product. This manual does not contain complete information about the system; it covers only the battery. For additional information about other devices, visit <http://www.sungrowpower.com> or the websites of the respective component manufacturers.

Purposes

This manual aims to provide detailed guidance on the installation, operation, and maintenance of the following product.

- MBL050
- MBL120
- MBL160

Target Group

This manual is intended for professional technicians who are responsible for the installation, operation, maintenance of the product. Qualified personnel must:

- Have received training in the installation, commissioning, and hazard handling of electrical systems;
- Be familiar with the manual and other related documents;
- Be familiar with local laws, regulations, and codes.

How to Use This Manual

Read this document thoroughly before using the product. Keep this document properly for the convenience of operations and maintenance.

All contents, pictures, marks and symbols in the manual are owned by SUNGROW. Any reproduction or disclosure, even partially, of the contents of this manual by personnel other than SUNGROW staff is strictly prohibited without the prior written authorization of SUNGROW.

The figures in this manual are for reference only. The actual product received may differ.

Contents of the manual may be updated and amended continuously, so it is possible that there may be some errors or slight inconsistency with the actual product. Please refer to the actual product purchased. Visit support.sungrowpower.com for the latest version of the manual.

Symbol Explanations

This manual contains important instructions, which are highlighted with relevant symbols, to ensure personal and property safety during usage, or to help optimize the product performance in an efficient way.

Below is a list of symbols that are used in this manual. Review them carefully to make better use of this manual.

⚠ DANGER

"DANGER" indicates high-risk potential hazards that, if not avoided, may lead to death or serious injury.

⚠ WARNING

"WARNING" indicates moderate-risk potential hazards that, if not avoided, may lead to death or serious injury.

⚠ CAUTION

"CAUTION" indicates a slightly hazardous situation that, if not avoided, may result in minor or moderate injury.

NOTICE

"NOTICE" indicates potential risks that, if not avoided, can lead to device malfunctions or financial losses.

"NOTE" indicates additional information, emphasized contents, or tips that may be helpful, e.g., to help you solve problems or save time.

Signal Definition

- BMS: Battery Management System
- SOC: State Of Charge
- SOH: State Of Health

1 Safety Instructions

Follow strictly the relevant safety instructions during the process of product installation, commissioning, operation, and maintenance. Improper use or incorrect operation may result in:

- Injury to or death of the operator or other people.
- Damage to the product, or to the property that belongs to the operator or a third party.

Strictly follow the safety instructions stated in the manual to avoid the hazards mentioned above.

WARNING

Do not perform any operation on the product (including but not limited to, handling, installing, powering on, and maintaining the product, performing electrical connection, and working at heights) in harsh weather conditions, such as thunder and lightning, rain, snow, and Level 6 or stronger winds. SUNGROW shall not be held liable for any damage to the product due to force majeure, such as earthquakes, floods, volcanic eruptions, mudslides, lightning strikes, fires, wars, armed conflicts, typhoons, hurricanes, tornadoes, and other extreme weathers. In case of fire, evacuate the building or product area and call the fire department. Do not go back to the fire area.

Tighten the screws at the specified torques using proper tools when fastening the product and terminals. Otherwise, the product may be damaged. The damage caused therefrom will not be covered by the warranty.

Understand how to use the tools properly first before starting using them, to avoid causing personal injury or product damage.

Before leaving the site during installation, implement necessary safety measures (e.g., lock the equipment doors).

NOTICE

Perform operations on the product only if you have a good understanding of this manual and appropriate tools in hand.

- Safety instructions in this manual should only serve as a supplement and are not all-encompassing regarding all the norms that need to be followed. All work should be carried out considering the actual situation on the site.
- SUNGROW shall not be held liable for any damage caused by violation of general safe operation requirements, safety standards, and the safety instructions specified in this manual.
- Product installation, operation, and maintenance should be conducted in compliance with applicable local laws, regulations, and specifications. Safety instructions in this manual should only be a supplement to the local laws, regulations, and specifications.
- During the product transport, installation, wiring, and maintenance, etc., the materials and tools prepared by users must meet the requirements of applicable local laws and regulations, safety standards, and other relevant specifications. SUNGROW shall not be held liable for any damage to the product caused by the adoption of materials and tools that fail to meet the above-mentioned requirements.
- Operations on the product, including but not limited to, handling, installing, wiring, powering-on, maintenance, and use of the product, must not be performed by unqualified personnel. SUNGROW shall not be held liable for any damage to the product resulting from operations done by unqualified personnel.
- Where the transport of the product is arranged by users, SUNGROW shall not be held liable for any damage to the product that is caused by users themselves or the third-party transport service providers designated by the users.
- SUNGROW shall not be held liable for any damage to the product caused by the negligence, intent, fault, improper operation, and other behaviors of users or third-party organizations.
- SUNGROW shall not be held liable for any damage to the product arising from reasons unrelated to SUNGROW.
- When fastening the product and terminals, tighten the fasteners at the specified torques. Otherwise, the product may be damaged, and such damages will not be covered by the warranty.
- Understand how to use the tools properly first before starting using them, to avoid causing personal injury or product damage.

1.1 Notices for Safe Use

Read all safety instructions carefully prior to any work and observe them at all times when working on or with the battery. Failure to observe the precautions described in this section can cause serious injury to persons or damage to property.

⚠ DANGER**Risk of explosion**

- Do not subject the battery to any strong force.
- Do not mechanically damage the battery (pierce, deform, strip down, etc.)
- Do not heat the battery or dispose of the battery in a fire.
- Do not install the battery in potentially explosive environments.
- Do not place the battery in water or other liquids.

⚠ DANGER**Risk of fire**

- Do not place the battery near a heat source, such as direct sunlight, a fireplace, a thermally uninsulated wall exposed to sunlight, hot water, or a heater.
- Keep sources of ignition such as sparks, flames, and smoking materials away from the battery.

⚠ DANGER**Risk of electric shock**

- Do not disassemble the battery.
- Do not handle a wet battery or use wet tools.
- Do not soak the battery in water or expose it to moisture or liquids.
- Keep the battery away from children and animals.
- Wear suitable clothing, guards and gloves to prevent you from direct contact with the DC voltage.
- Use insulated tools during working with battery.
- Set aside metal jewelry before working on the DC circuit.

1.2 Battery Handling

NOTICE

Use the battery according to local standards.

Any man-made damage will void the limited warranty of the battery. Handle the battery with care to prevent damage.

- Use the battery only as intended and designed.
- Install the battery only in a suitable location.
- Ensure the battery is properly grounded before use.
- Do not use the battery if it is defective, cracked, broken, damaged, or inoperable. Do not use the battery with other types of batteries.
- Do not pull, drag, or step on the battery.

- Do not leave any foreign objects inside the battery.
- Do not repair or modify the battery, as it is not user-serviceable.
- Do not unplug any cables when the battery is powered on.
- Do not damage the sheaths of cables, wire harnesses, and connectors.
- Keep the battery away from materials prone to discharge, including electrostatic discharge, during charging, use, and storage.
- Keep the battery away from infants and children to prevent accidents.
- Cover the terminals with insulating tape before proper handling.
- Avoid direct contact with rain, snow, and water, and prevent the battery from falling or being subjected to mechanical impact during transportation.

1.3 Emergencies

1.3.1 Leaking Batteries

Abuse/misuse/damage of the battery may cause increasing of internal pressure in the battery cells. It may result in the electrolyte venting. In the event that battery electrolyte is released:

- Do not enter the room under any circumstance.
- Avoid contact with the leaking liquid or gas.
- Call the Local Emergency number or Fire Brigade if necessary.

If one is exposed to the leaking substance, follow the suggestions below to minimize the chance of injury:

- Inhalation: Evacuate the contaminated area, and seek medical aid.
- Eye contact: Rinse eyes with copious amounts of water for at least 15 minutes, and seek medical aid immediately.
- Skin contact: Wash the affected area thoroughly with plenty of water for at least 15 minutes. If possible, remove or saturate contaminated clothing with water. Seek medical aid if the patient is distressed.
- Ingestion: Induce vomiting, and seek medical aid immediately.

Wipe out the contacted area with a sponge or cloth that is soaked in water until you obtain medical aid. These materials can damage skin and eyes, causing blindness.

1.3.2 Fire

Fire may occur with the battery despite its careful design. Likewise, a fire or unusually high temperatures near the battery can cause it to catch fire.

Protective equipment

A respirator is not required during normal operations.

In the event of a fire, hazardous fumes including carbon monoxide, carbon dioxide, and/or various hydrocarbons may be emitted. To comply with the Personal Protective Equipment Directive (89/686/EEC), use a full-face self-contained breathing apparatus (SCBA) with full protective gear during fire fighting.

Fire fighting

NOTICE

In the event of a fire, only qualified firefighters with appropriate protective equipment are permitted to enter the room where the battery is located. It may take a long time to completely extinguish the fire. Consider allowing the system to burn. Smoke indicates that the battery is still burning. Always note that there is a risk of the battery re-igniting.

Proceed as follows for fire-fighting.

1. Shut off any connected power system or electronics such as the battery, battery isolator, PV DC isolator(s), AC isolator, solar supply main switch and normal supply main switch.
2. Perform an adequate knock down on the fire before entering the incident's hot zone.
3. If the battery catches on fire, use fire-fighting sand, CO₂ extinguisher, or other emergency fire extinguishing equipment approved by fire fighters to extinguish the fire.
4. If the fire is not from the battery and has not spread to it yet, use an ABC fire extinguisher to extinguish the fire. Remove batteries and other ignition sources from the scene of a fire.

1.3.3 Wet Batteries

If the battery is submerged in water, do not let people access it, and then contact Sungrow or an authorized service partner for technical support.

If a battery is submerged in water or flooded, first, switch off all circuit breakers in the system to cut off the power supply to the battery. Wait until floodwaters subside and do not approach near battery. If someone needs to go into the flooded water, wear insulated full length rubber boots and gloves.

Do not use a flooded battery again.

1.3.4 Damaged Batteries

The battery consists of lithium-ion cells. These are considered dry cell batteries. If the battery is damaged, only a small amount of battery fluid can leak.

A damaged battery can cause rapid heating of the battery cells. If you notice smoke coming from the battery area, assume that the battery is burning and take appropriate action as described in [1.3.2 Fire](#).

Damaged batteries are dangerous and must be handled with extreme caution. They are not fit for use and may pose a danger to people or property. If a battery seems to be damaged:

1. Pack it in its original container.
2. Store it in a separated room like the installation place.
3. Contact SUNGROW.

 DANGER

**A damaged battery may release dangerous material and a flammable gas mixture.
Never try to repair the battery even if you are a qualified electrician.**

2 Product Description

2.1 System Introduction

As an important part of the PV power generation system, MBL050/120/160 batteries work in conjunction with the hybrid inverter to store energy and supply it later.

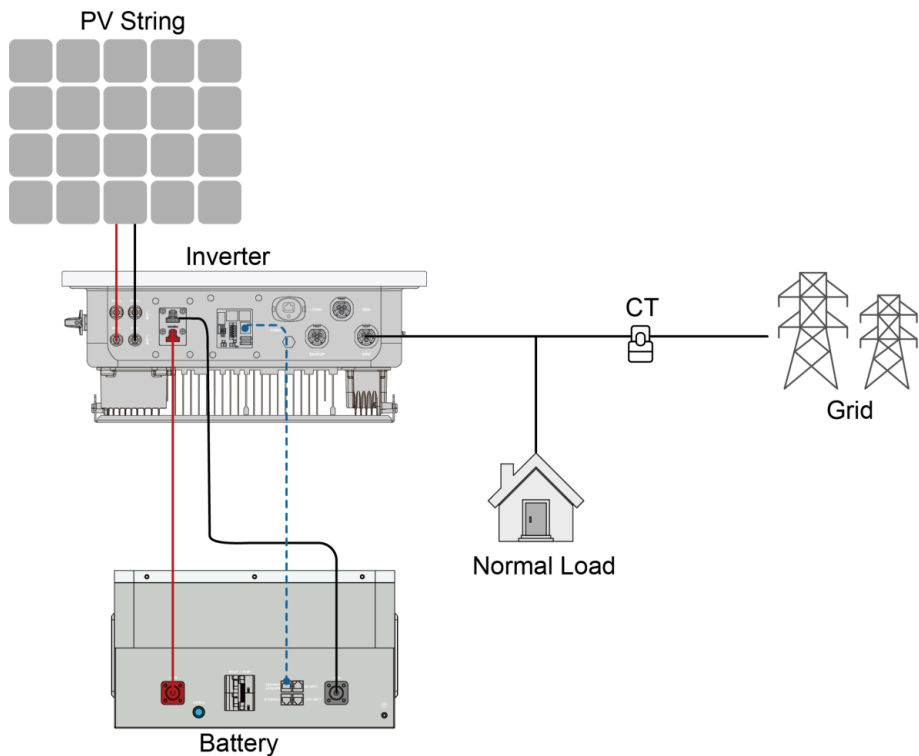

Figure 2-1 System Wiring Diagram

2.2 Product Introduction

Product Appearance

The appearance of the product is shown in the figure below:

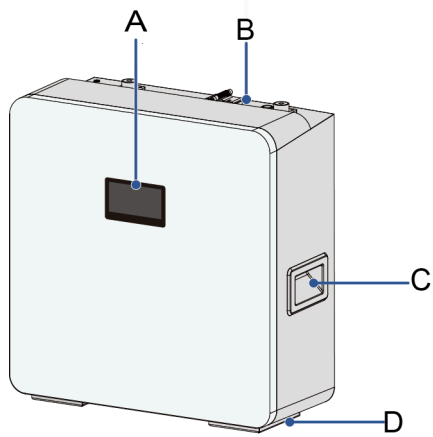

Figure 2-2 MBL050

*The figure shown is for reference only. The actual product shall prevail.

A: Operating screen

B: Wiring area

C: Carrying handle

D: Rubber feet

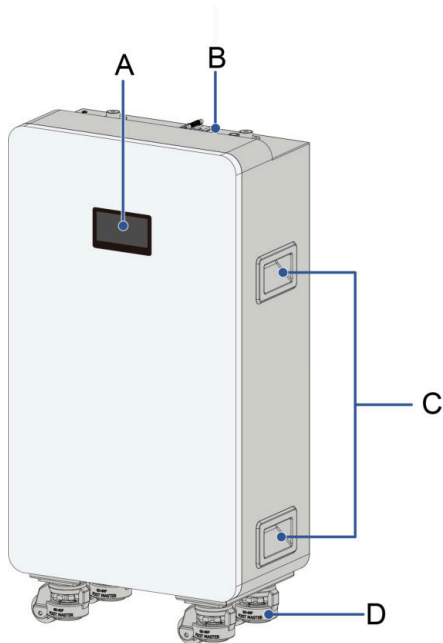

Figure 2-3 MBL120/160

*The figure shown is for reference only. The actual product shall prevail.

A: Operating screen

B: Wiring area

C: Carrying handle

D: Leveling caster

Dimensions

The dimensions of the battery are shown in the figure below:

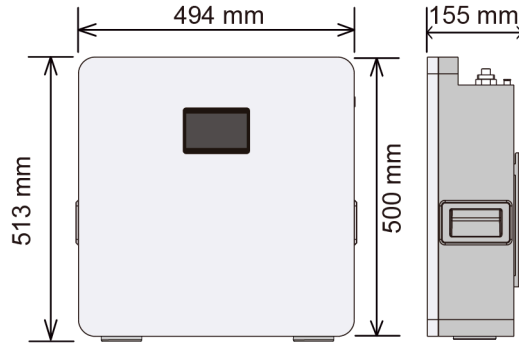

Figure 2-4 MBL050

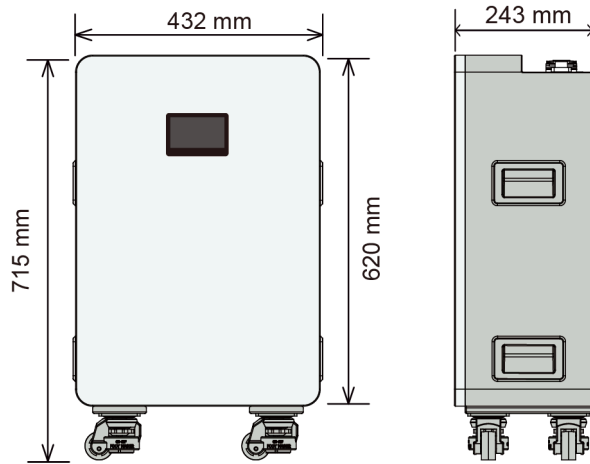

Figure 2-5 MBL120

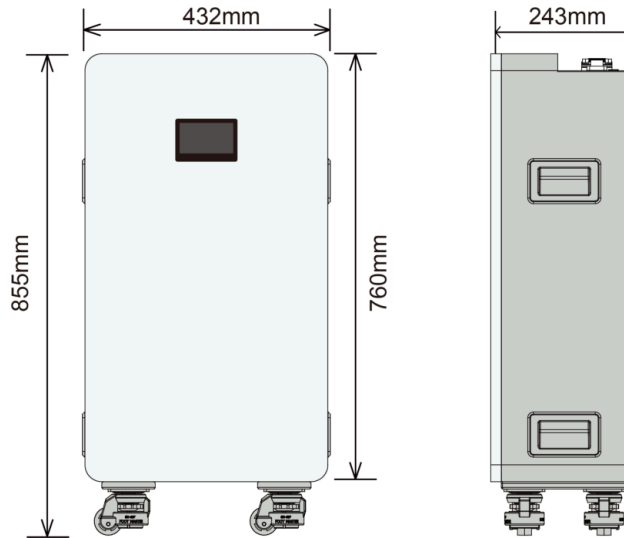





Figure 2-6 MBL160







*The figure shown is for reference only. The actual product shall prevail.

Weight

Model	Weight
MBL050	47.5kg
MBL120	86.5kg
MBL160	114.2 kg

2.3 Symbols on the Product

Symbols	Description
	CE mark of conformity. EU/EEA importer.
	Danger! Do not work on the product when it carries voltage.
	Electric shock hazard! Service must be performed only by qualified personnel. Keep it out of reach of children.

Symbols	Description
	No open flames! Avoid exposure to flames, incineration, punctures, or impacts.
	Read through the user manual before maintenance.
	Please recycle this lithium-ion battery. Do not discard.
	Do not dispose of it in the trash. Compacting a lithium-ion battery is dangerous as it can explode.
	Do not dispose of the battery as household waste.
	This is a protective grounding terminal, which should be grounded securely to protect the safety of operators.

NOTICE

You may affix warning labels in accordance with local installation codes or standards.

2.4 Screen Display Description

The MBL050/120/160 battery features a touch screen, which allows you to view battery information and system status, and configure system settings.

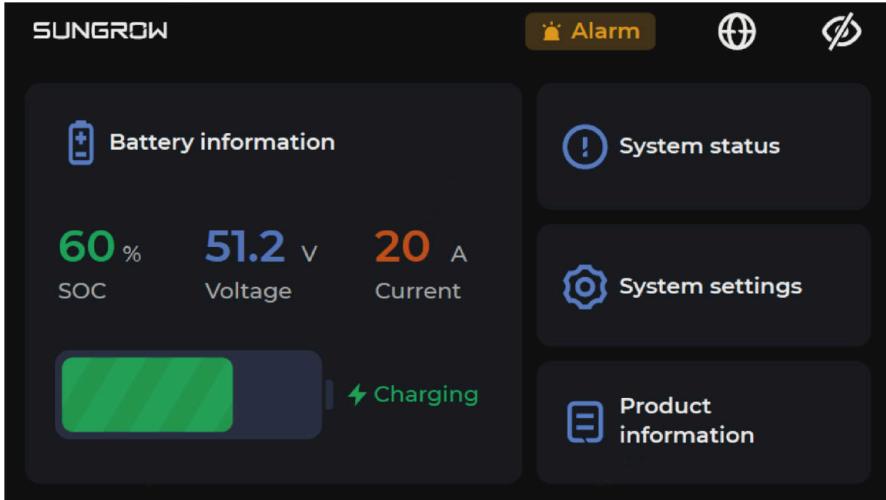

3 Unpacking and Storage

3.1 Unpacking and Inspection

The product has undergone strict tests and inspections before delivery. However, as it may still get damaged during transportation, please carry out a thorough inspection before signing the delivery receipt.

- Inspect the packaging for any damage.
- Check the delivered items for quantity and see if the delivery matches the order placed according to the packing list.
- Unpack and inspect the items inside for any damages.

Contact the transport company or SUNGROW in case of any damages or missing items, and provide relevant photos or the name/quantity of the missing items for better services.

Do not throw away the original packaging box. It is recommended to store the device in its original packaging after it is decommissioned.

NOTICE

Inspect the product for any external damages or damages to the structural parts, and check if the packing list matches the order placed. In case of any problem with the above-mentioned inspection items, do not install the device and contact SUNGROW in time.

Be careful not to damage the device while using tools for unpacking.

3.2 Scope of Delivery

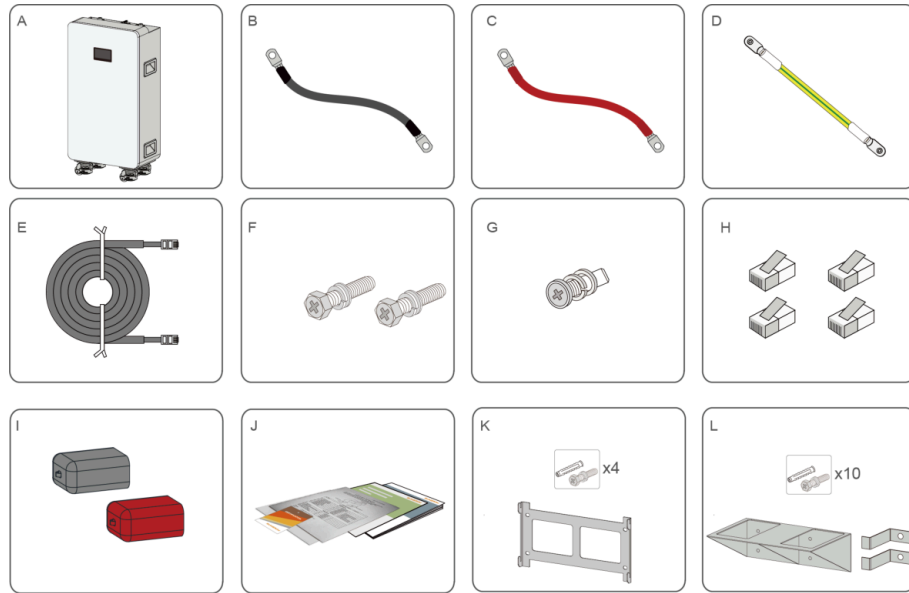

Figure 3-1 Packing List

No.	Name	Quantity	
A	Battery	1	
B	Power cable (black)	1	
C	Power cable (red)	1	
D	Yellow-green PE cable	1	
E	Communication cable	2	
F	MBL050: Screw (M6x12) MBL120/160: Screw (M8x16)	2	
G	Screw (M5x10)	1	
H	RJ45 connector	4	
I	Waterproof terminal	2	
J	Document	1	
K	Mounting bracket kit (standard for MBL050)	Mounting bracket	1
		Screw (M8x80)	4
L	Mounting bracket kit (optional for MBL120/160)	Mounting bracket	1
		Mounting ear	2

No.	Name	Quantity
	Screw (M8x80)	10

* The figure shown is for reference only. The actual product shall prevail.

3.3 Storage Requirements

If the battery is not installed immediately, proper storage is required.

- Store the battery in its original packaging box with desiccant inside.
- Do not expose the battery directly to sunlight or rain.
- Do not store the battery near harmful gases, flammable, or explosive products. Protect the battery from mechanical shock, high pressure, strong magnetic fields, and direct sunlight.
- Store the battery in an environment with a suitable temperature, and ensure the storage time does not exceed the following limits:
 - When stored at 25°C, the maximum storage time is 6 months.
 - When stored at 35°C, the maximum storage time is 3 months.
 - When stored at 45°C, the maximum storage time is 1 month.
- If stored under the specified conditions for longer than the required time above, charge the battery until the system SOC is 50%. Preferably, use an inverter for forced charging.
- The relative humidity during storage must always be between 5% and 95%, with no condensation.
- Do not place the battery upside down or on its side during storage.
- Inspect the packaging regularly for any damage. If any damage is found, replace the product immediately.

4 Mounting

4.1 Safety during Mounting

⚠ WARNING

This product or system must be operated by professionals!
Failure to follow the safety instructions in this manual or operation of this product or system by non-professionals may cause severe personal injury or major property damage.

⚠ WARNING

Strictly follow local relevant standards and requirements in the whole process of installation.

4.2 Installation Location Selection

Select the optimal installation location to ensure safe operation, a long service life, and optimal performance of the battery.

- Batteries with an IP20 rating are only suitable for dry indoor environments.
- Do not place the battery in areas prone to prolonged water accumulation.
- Do not install the battery in flammable and explosive areas.

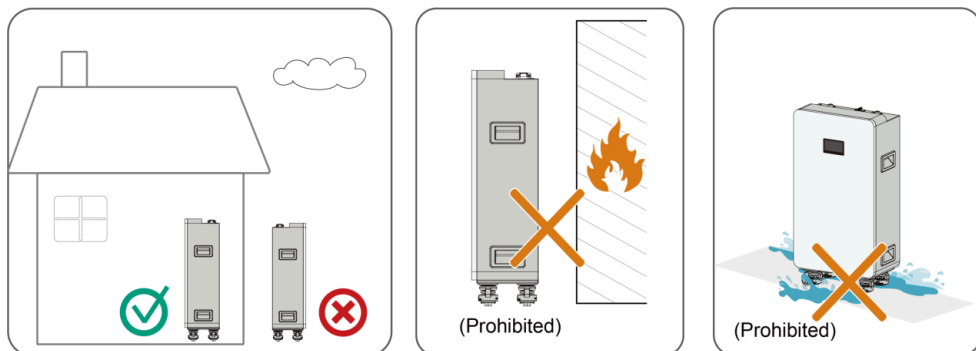

- Install the battery system in an area that facilitates electrical connections, operation, and maintenance.
- Do not place the battery in areas accessible to children.

Installation Environment Requirements

- Avoid direct exposure to sunlight, rain, and snow.
- Place the battery in a well-ventilated area to ensure air circulation.

- The allowable temperature and humidity range are shown in the figure below:

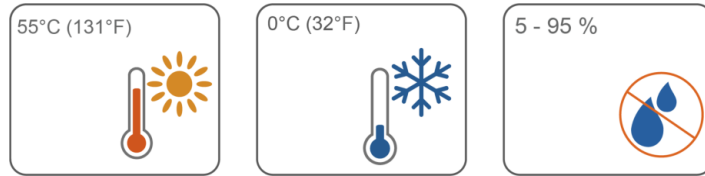

The battery system may derate if the ambient temperature is below 15°C or above 45°C.

Installation Space Requirements

Make sure there is sufficient space around the battery for good ventilation and heat dissipation. The installation space for the battery system is shown in the figure below.

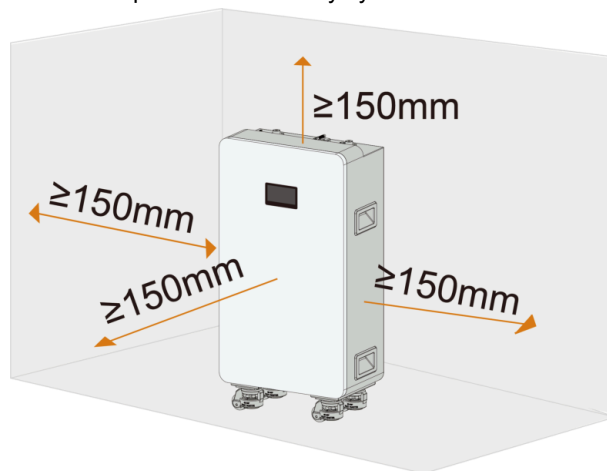

When installing multiple batteries, reserve sufficient space between them.

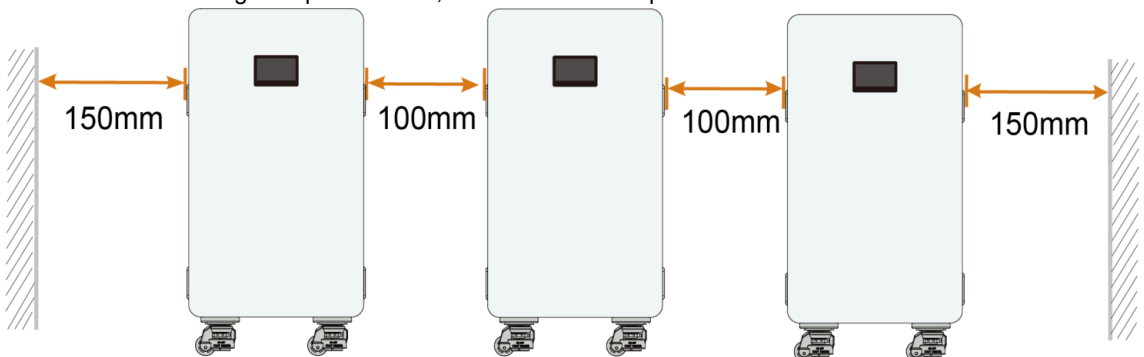

Wall-Mounted Installation Requirements

- For wall-mounted installation, no clearance is required between the battery and the floor.
- The load-bearing capacity of the installation structure shall be at least twice the weight of the battery, and the installation structure shall be compatible with the battery dimensions.

- Do not install the battery on a structure that may generate resonance, to prevent excessive noise.

4.3 Installation Tools

Installation tools to be used include but are not limited to those listed below. If necessary, use other auxiliary tools on site.



Safety goggles

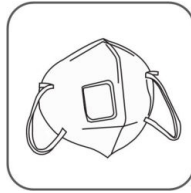

Dust mask



Safety gloves



Safety shoes



Phillips
screwdriver
(ST6.3,M5,M8,
M10)



Level

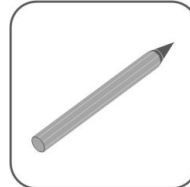

Marker

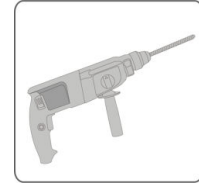

Hammer drill



Rubber mallet

4.4 MBL050 Battery Installation

Step 1 Place the mounting bracket against the wall, use a level to determine the installation position of the bracket and mark the screw holes.

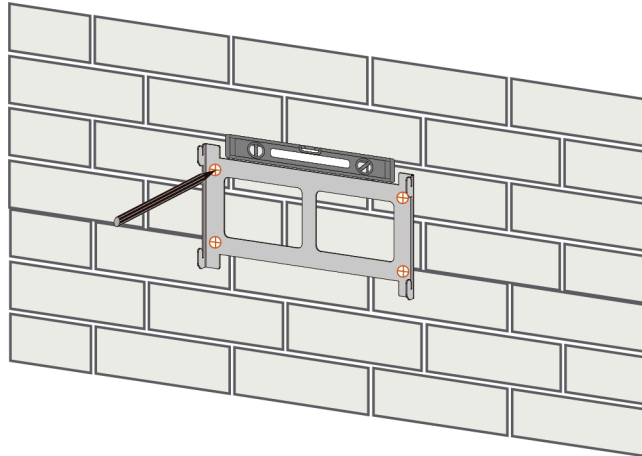

Step 2 Drill holes at the marked positions on the wall and fix expansion sleeve anchors.

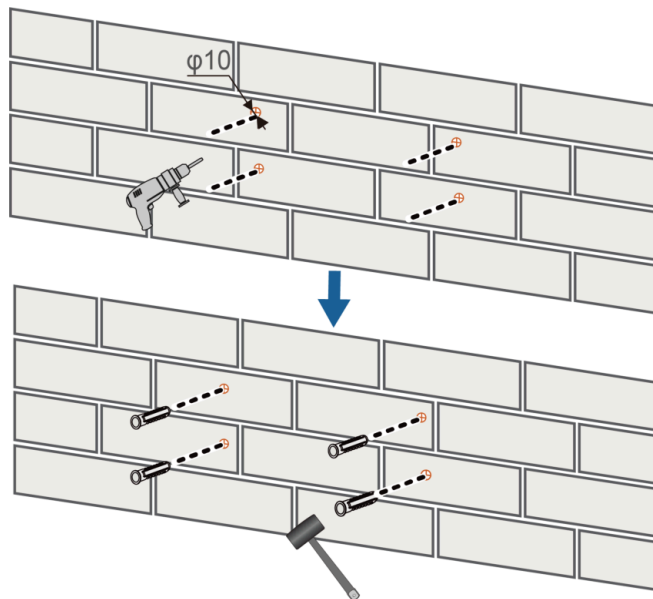

* The depth of the holes should be about 80 mm.

Step 3 Secure the bracket on the wall using M8 screws.

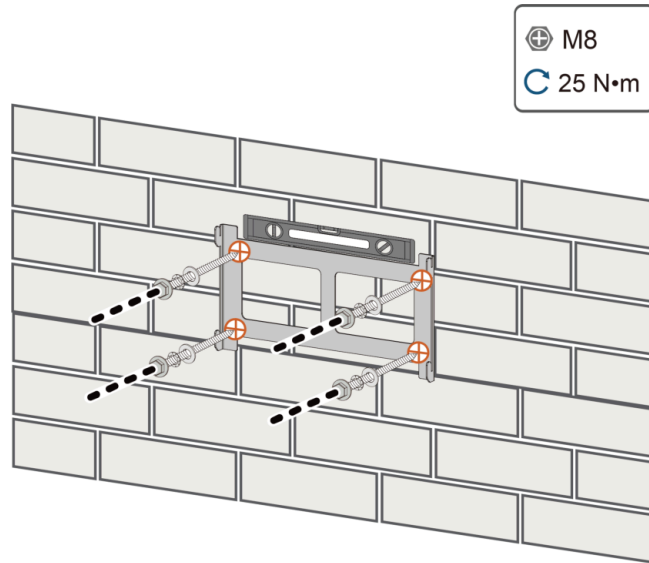

Step 4 Align the four mounting holes on the rear of the battery with the mounting bracket, then lower the battery vertically until it is securely seated on the bracket.

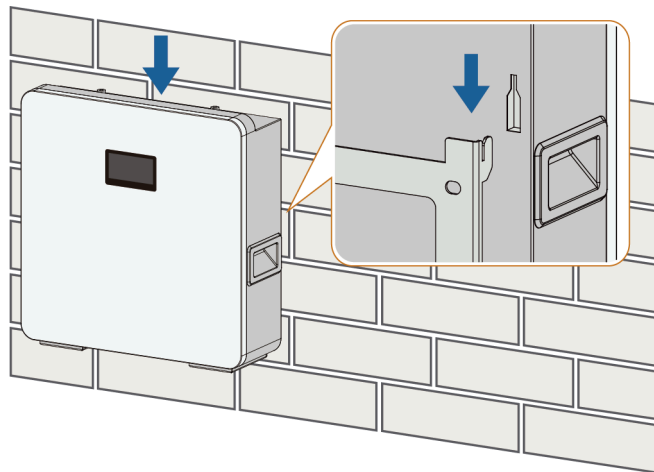

--End

4.5 MBL120/160 Battery Installation

4.5.1 Method 1: Floor-Mounted Installation

Prerequisite

Select a suitable environment before starting the installation.

Step 1 The battery is pre-installed with leveling casters. Push it from the left or right side to a suitable installation location.

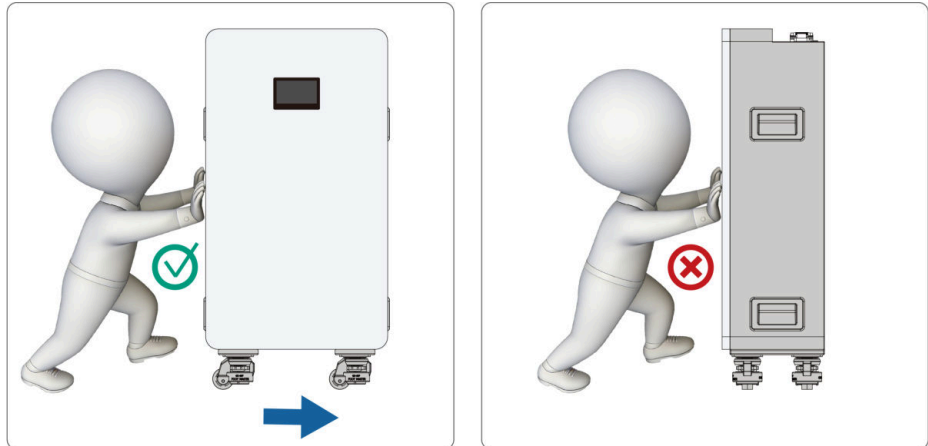

Figure 4-1 Correct Pushing Method

NOTICE

Do not push the battery from the front; otherwise, the battery may tip over due to uneven force.

Step 2 Rotate the adjustment gear in the middle of the leveling caster so that its bottom touches the ground, preventing the battery from moving.

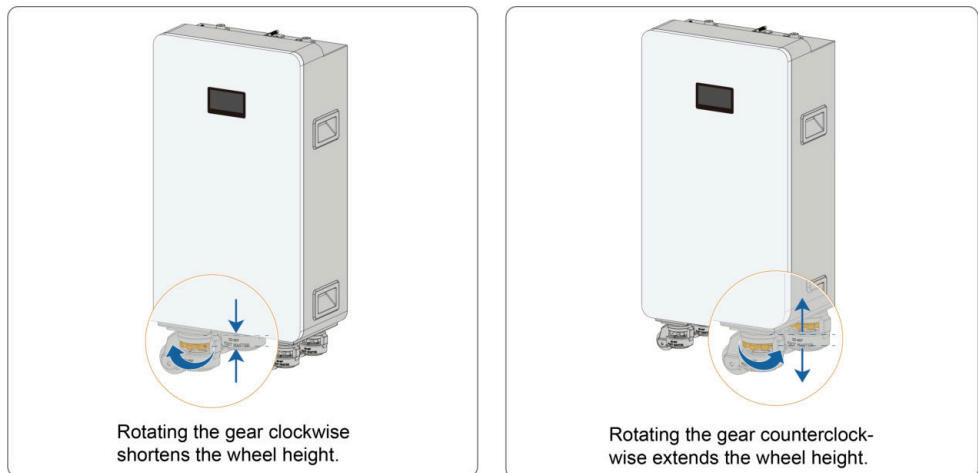

Figure 4-2 Gear Adjustment

- If the installation ground is uneven, rotate the adjustment gear in the middle of the leveling caster (adjustment range: 0 to 10 mm) to level the battery.
- After leveling, ensure that the battery remains vertical. Prolonged tilting or tipping over may degrade battery performance.

--End

4.5.2 Method 2: Wall-Mounted Installation (Optional)

Prerequisite

For wall-mounted installation, the mounting bracket kit for MBL120/160 shall be purchased.

Step 1 Place the mounting bracket against the wall, use a level to determine the installation position of the bracket and mark the screw holes.

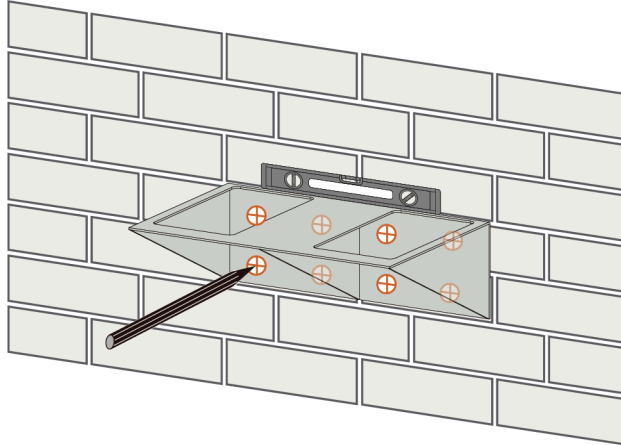

Step 2 Drill holes at the marked positions on the wall and fix expansion sleeve anchors.

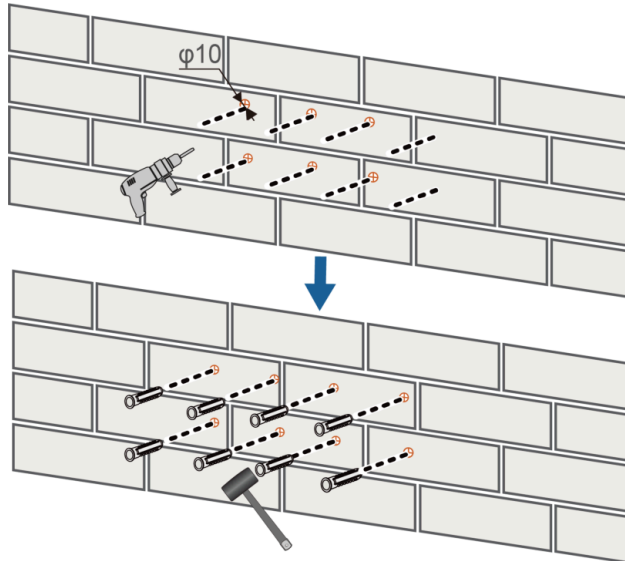

* The depth of the holes should be about 80 mm.

Step 3 Secure the bracket on the wall using M8 screws.

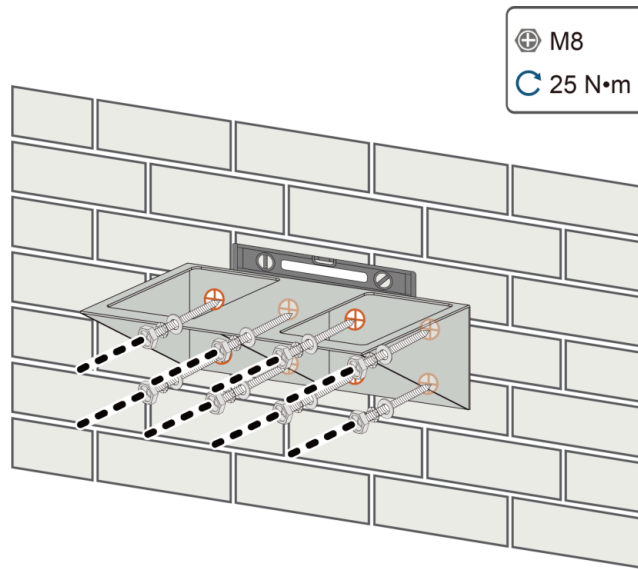

Step 4 Place the battery on the mounting bracket.

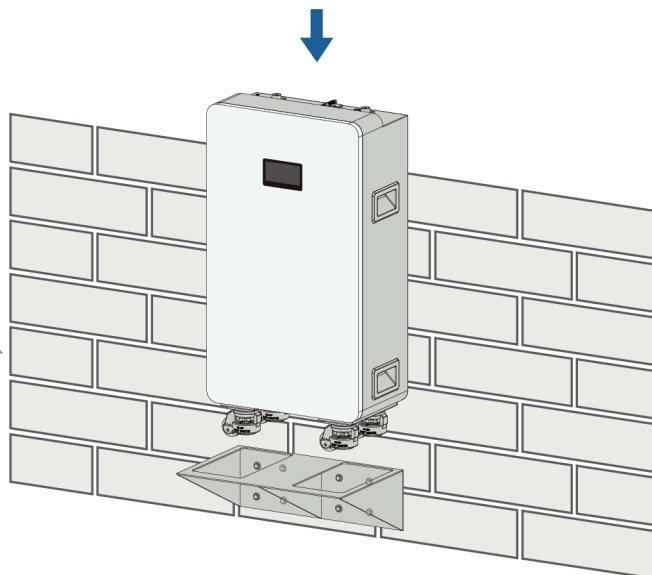

Step 5 Position the mounting ears on both sides of the carrying handles in the first row of the battery, and mark the screw holes.

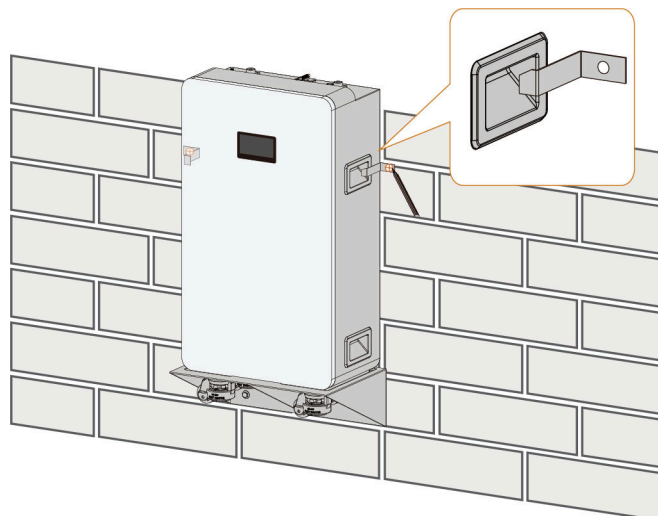

Step 6 Drill holes at the marked positions on the wall and fix expansion sleeve anchors.

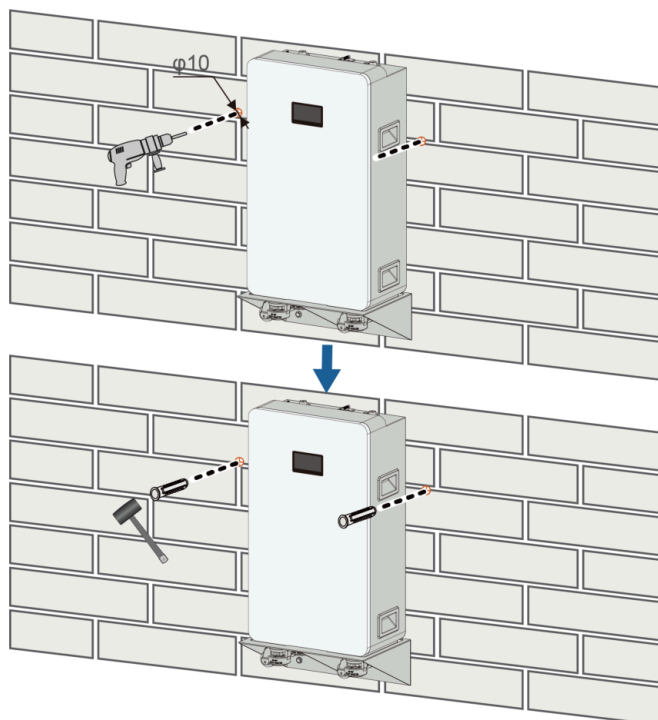

* The depth of the holes should be about 80 mm.

Step 7 Secure the mounting ears using M8 screws. Installation is complete.

M8
C 25 N•m

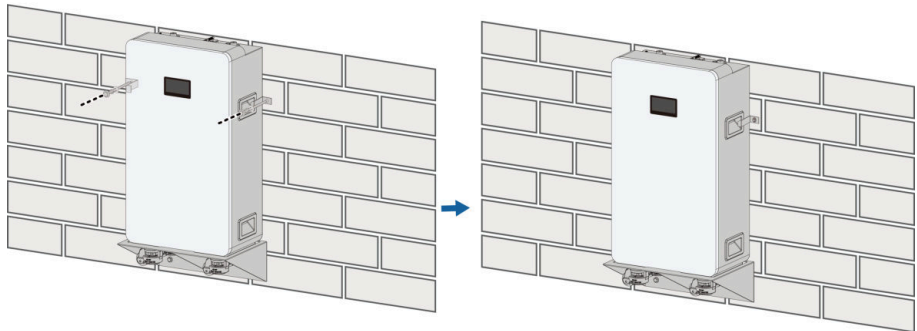

--End

5 Electrical Connection

5.1 Safety Precautions

⚠ DANGER

- Operators must wear proper personal protective equipment when performing electrical connections.
- Before touching the DC cables, the operator must use a measuring instrument to ensure that the cable is de-energized.
- Before performing any electrical operation, ensure that the battery system is not damaged and that all cables are de-energized.
- The battery provides electrical power. A short circuit or incorrect installation of the battery may cause burns or fire hazards.

⚠ WARNING

- Product damage caused by incorrect wiring is not covered by the warranty.
- Electrical connections must be performed by qualified technical persons.
 - All cables used in the system must be securely connected, properly insulated, and of the correct size.

NOTICE

- All electrical connections must be done in compliance with the applicable local national/regional electrical standards.
- All unused terminals must be covered with waterproof covers to prevent affecting the protection rating.
 - When routing communication cables, separate them from power cables and keep them away from strong interference sources to prevent communication interruption.
 - Cables used by the user shall comply with the requirements of local laws and regulations.
 - The cable colors in the figures in this manual are for reference only. Select cables according to local cable standards.

5.2 Terminal Description

Electrical terminals are on top of the battery, as shown below.

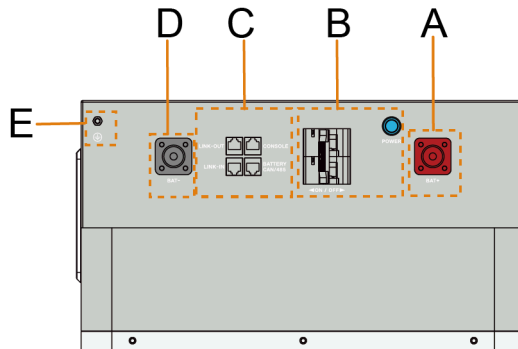



Figure 5-1 Terminal Description

*The figure shown is for reference only, and the actual product shall prevail.

No.	Name	Marking	Description
A	Battery input terminal	BAT+	Connects to the positive BAT terminal of the hybrid inverter.
B	Start button and circuit breaker	POWER OFF/ON	Turn the battery on or off.
C	Communication port	BATTERY CAN/485	Connects to the communication port of the hybrid inverter.
		LINK-IN LINK-OUT	For communication connection between batteries connected in parallel.
		CONSOLE	Connects to the communication port of the computer.
D	Battery input terminal	BAT-	Connect to the negative BAT terminal of the hybrid inverter.
E	Protective earthing terminal		Used for reliable grounding of the battery system.

5.3 Electrical Connection Overview

The electrical connection between the battery system and the inverter is illustrated in the figure below.

The following figure uses the MG5/6RL inverter and MBL160 battery as an example to illustrate its connection with a single battery. This connection method is also applicable to the MG8/10/12RL inverter and MBL050/120 battery.

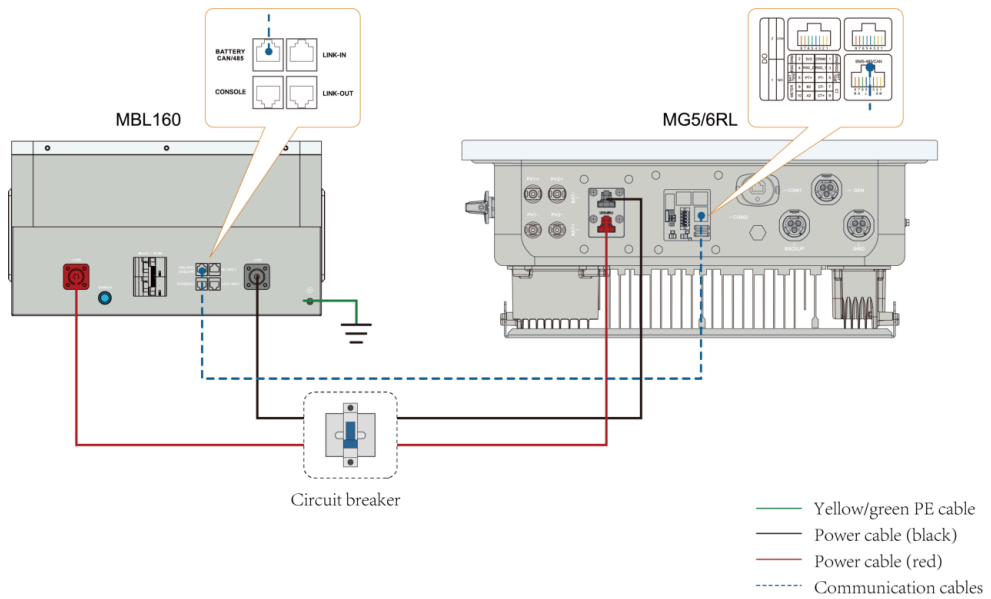
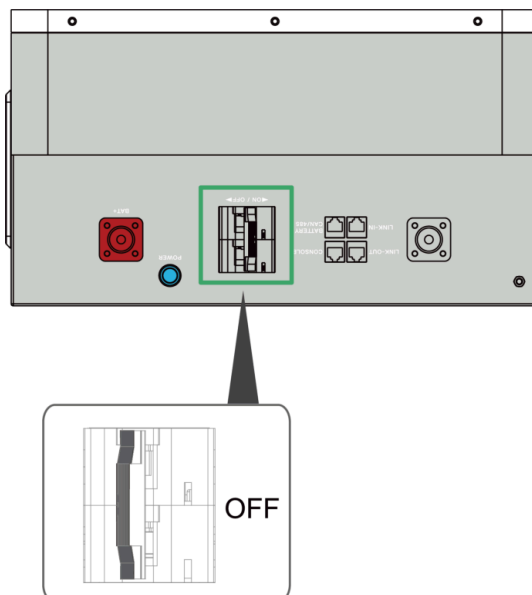

Figure 5-2 Electrical Connection Overview

* Users can connect an external circuit breaker via the power cable.

5.4 External Grounding

Step 1 Ensure the circuit breaker switch of the top terminal is in the OFF state.



Step 2 Secure the yellow-green PE cable with an M5 screw.

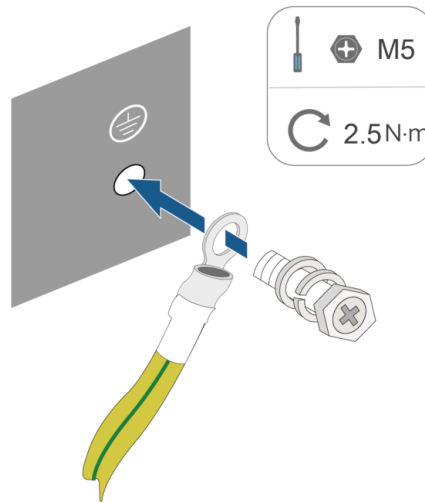

--End

5.5 Connecting Inverters to Batteries

This section describes the wiring method and specific operation steps for connecting the inverter to the battery.

5.5.1 Connecting MG5/6/8/10/12RL to a Single Battery

Refer to [Electrical Connection Overview](#) for the wiring between a single inverter and a single battery.

5.5.2 Connecting the MG8/10/12RL to Two Batteries

The MG8/10/12RL has two pairs of BAT terminal blocks. No additional terminal blocks are required when connecting it to two batteries.

Battery requirements: Before connecting two batteries in parallel, ensure that they have the same SOC and model, and the voltage difference between them is less than 1 V. If the battery SOC's are found to be inconsistent on site, handle it in any of the following ways:

- First, connect one battery to the inverter to charge or discharge it until its SOC matches the other battery, and then perform parallel wiring.
- Charge the batteries to the same SOC in the warehouse in advance, and then transport them to the site for installation.

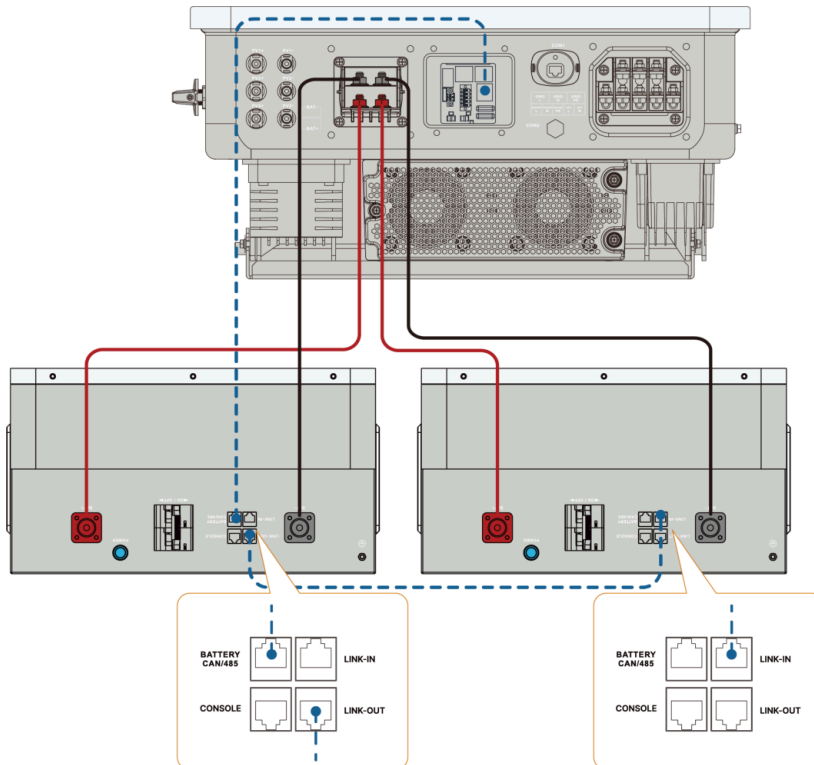

NOTICE

MG5/6RL has only one pair of BAT terminals, so an additional external wiring terminal block is required when connecting it to two batteries. For specific connection methods, refer to [5.5.3 Multi-Battery Cascading](#).

5.5.3 Multi-Battery Cascading

This section describes the wiring configurations for the MG8/10/12RL inverter with multiple batteries (more than two) or the MG5/6RL inverter with multiple batteries (two or more), as well as the methods for connecting multiple batteries in parallel.

Requirements for Multi-Battery Cascading

1. A maximum of 20 batteries can be connected in parallel.
2. It is recommended to select multiple batteries from the same batch for parallel wiring.
3. When multiple batteries are connected in parallel, terminal blocks are required. Please ensure that
 - The length of the power cable connecting each battery to the terminal block is consistent.
 - The wiring terminal block used must meet the charge and discharge current requirements when multiple batteries are connected in parallel.
4. Consistent battery status: Before connecting batteries in parallel, ensure that they have the same SOC and model, and the voltage difference between them is less than 1 V. If

the battery SOC are found to be inconsistent on site, handle it in any of the following ways:

- First, connect one battery to the inverter to charge or discharge it until its SOC matches the other battery, and then perform parallel wiring.
- Charge the batteries to the same SOC in the warehouse in advance, and then transport them to the site for installation.

Single Inverter Cascading with Batteries

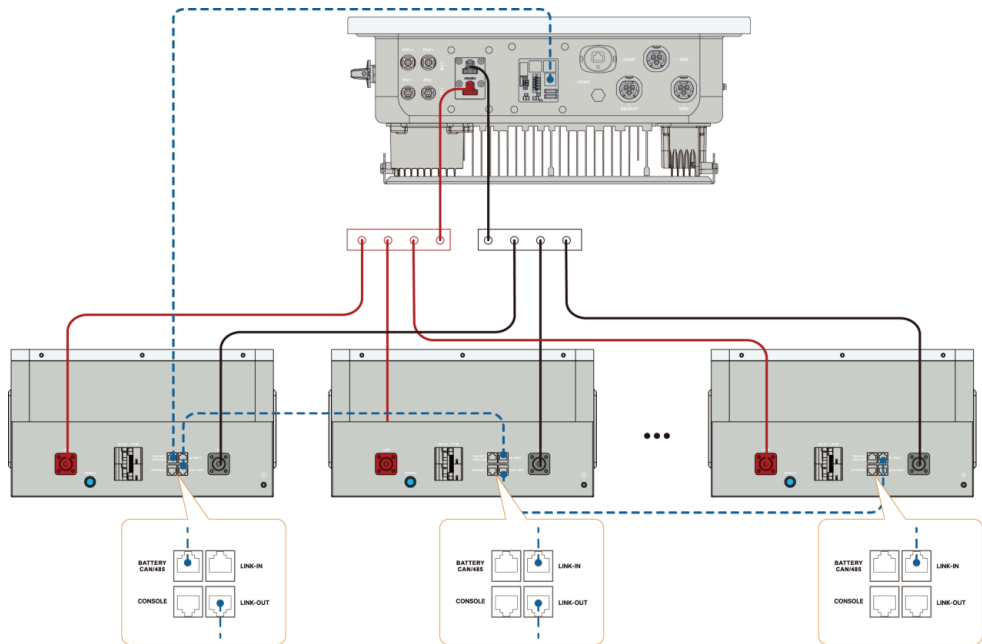

Multiple Inverters Cascading with Batteries

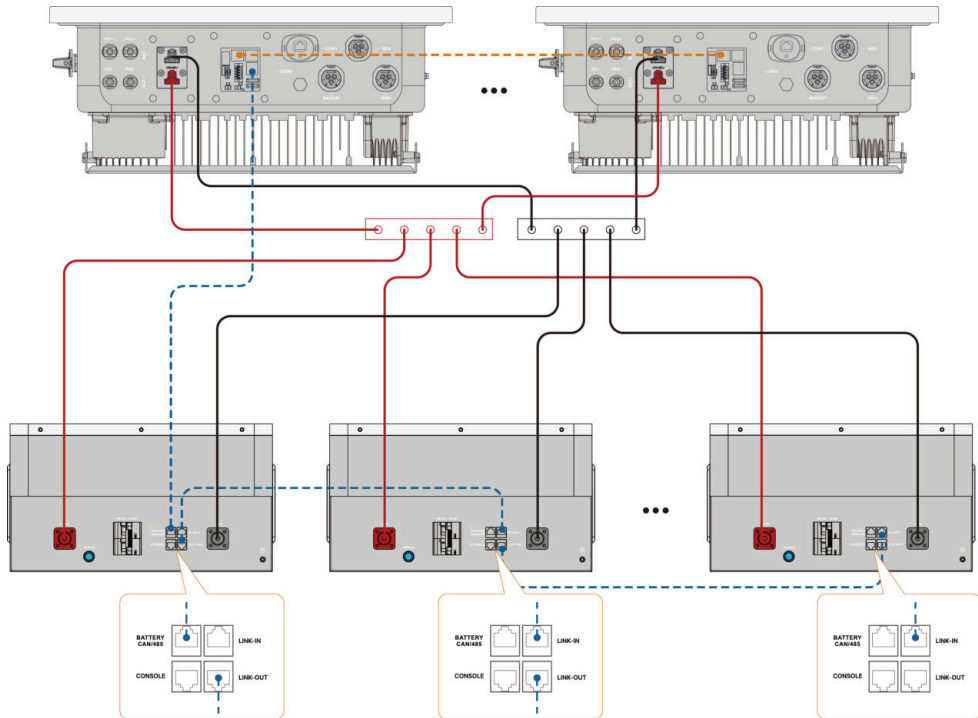

5.5.4 Cable Connection

This section describes the specific steps for connecting cables.

Step 1 Remove the plastic covers from the battery's DC port.

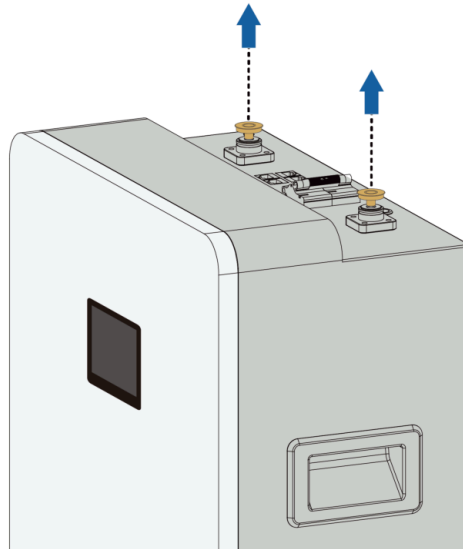

Step 2 Secure the power cable to the battery terminals using M8 screws.

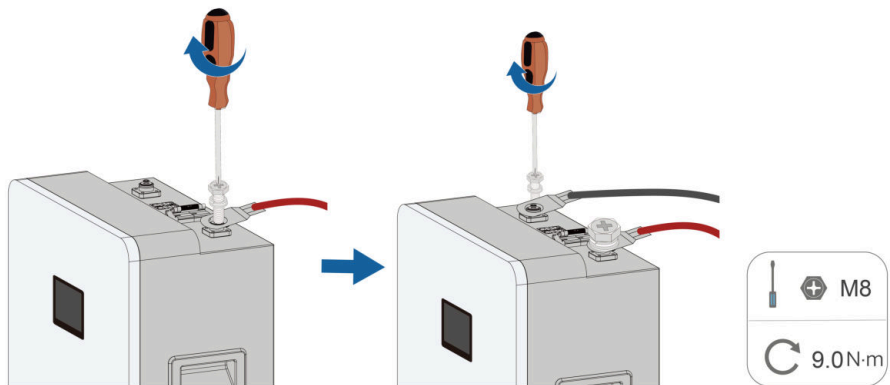

*The figure uses the MBL120/160 battery as an example. For MBL050, please use M6 screws, 5.0 N·m.

Step 3 Snap the waterproof terminal covers onto the wired terminals from the side; a “click” indicates that they are snapped in place.

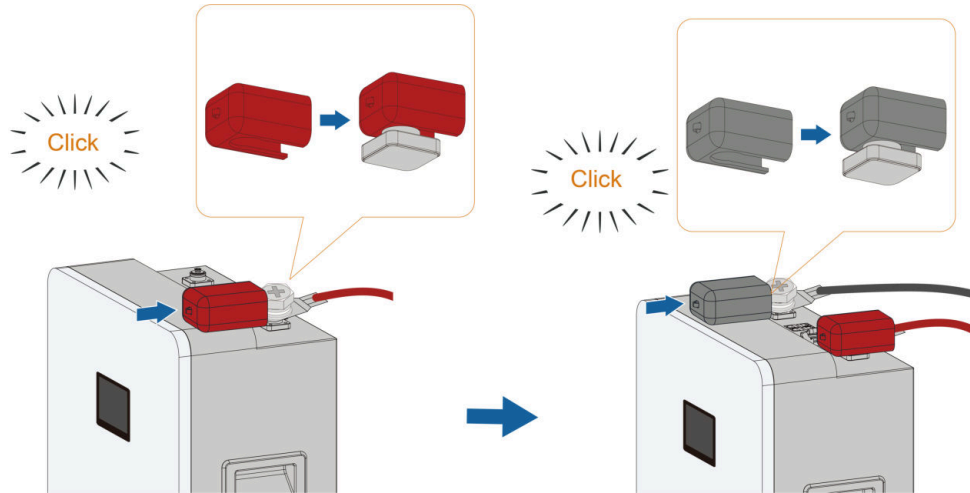

Step 4 Connect the other end of the power cable to the BAT terminal block of the inverter.

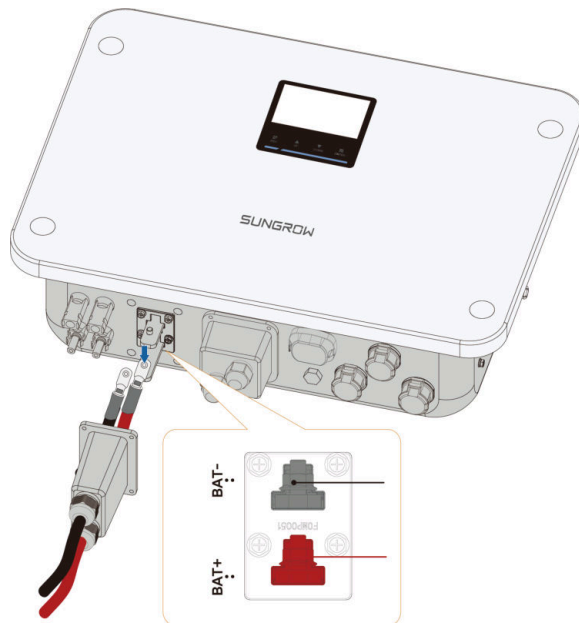

Step 5 Connect the communication cable. Connect the BMS-485/CAN communication port of the inverter to the communication port of the battery using the supplied communication cable.

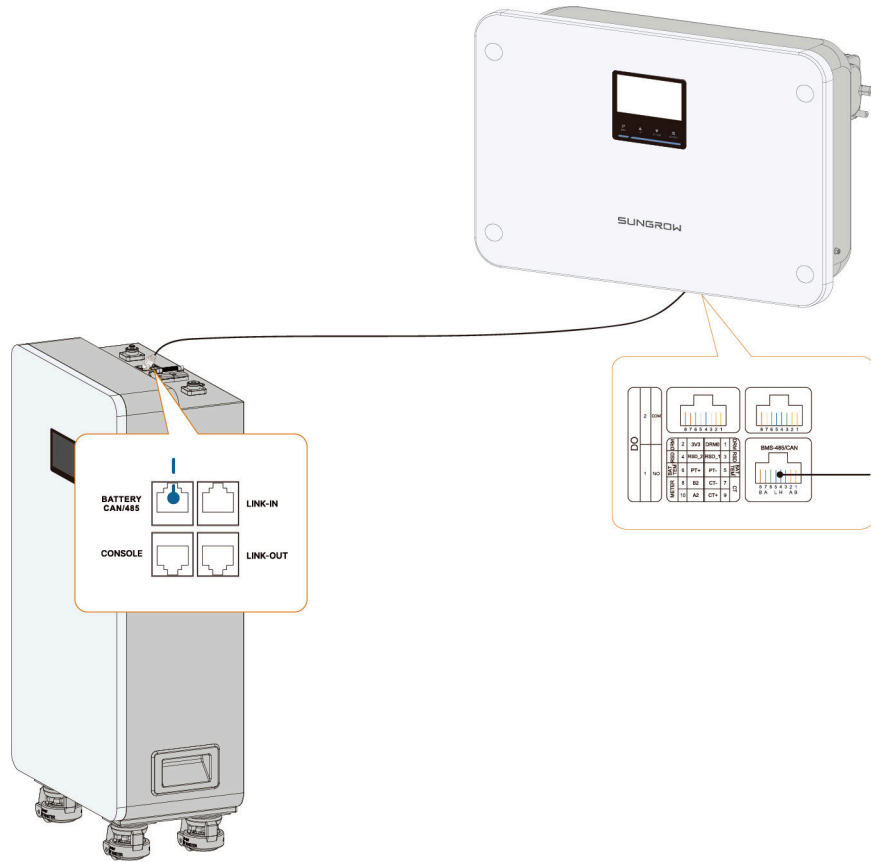

Step 6 Once the battery is connected, the inverter screen displays the battery status information.

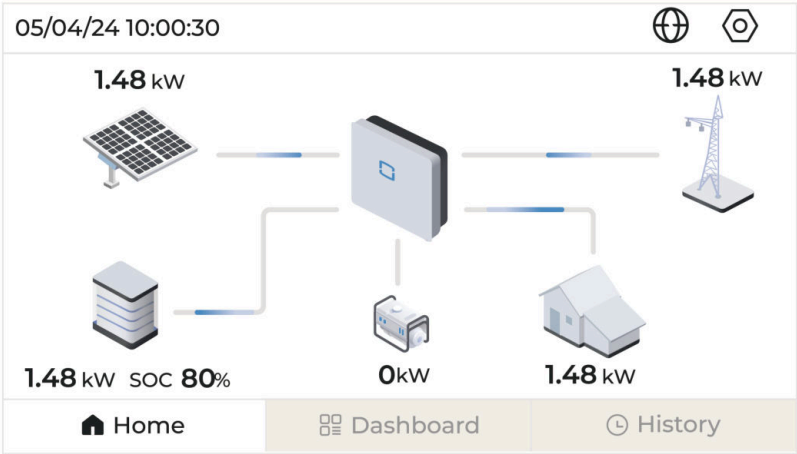

--End

6 Commissioning

6.1 Inspection before Commissioning

Check the following items before starting the battery:

- Check that the battery is installed completely.
- Check that the appearance of the battery is intact.
- Check that the battery system output cables are correctly connected to the positive and negative terminals of the battery and hybrid inverter. Avoid misconnection and reverse connection.

6.2 Commissioning Procedure

If the inspections for commissioning have been completed, and all of the above requirements have been met, please follow the steps below to start the battery system for the first time.

Step 1 Turn the circuit breaker to "ON".

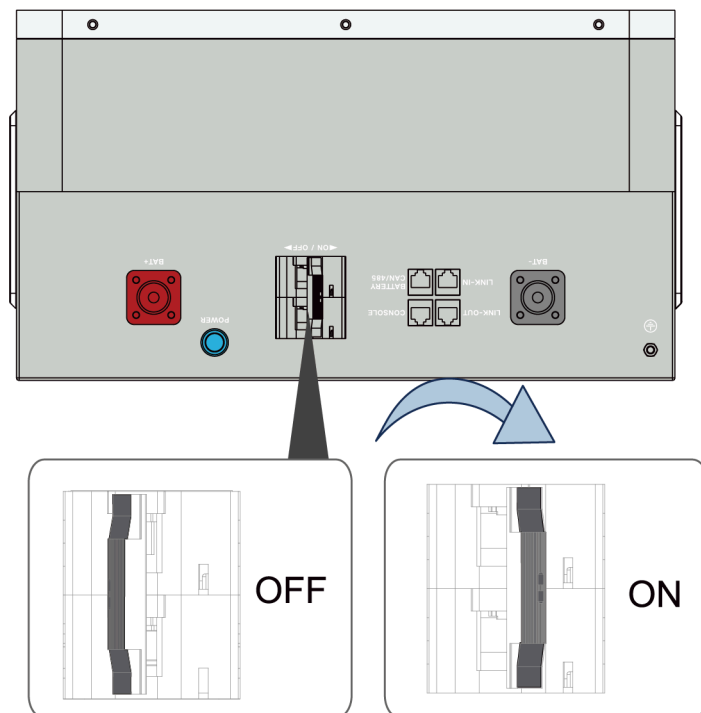

Step 2 Press the switch to start the battery.

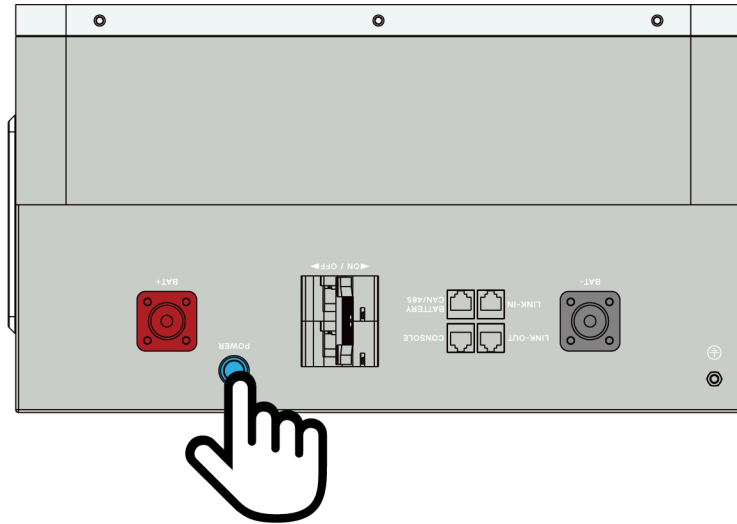
**NOTICE**

When starting the battery system for the first time, if multiple batteries are connected in parallel, turn on the circuit breaker of each battery and switch button of master battery.

--End

7 Screen Action

After the battery is turned on, you can change the language, view battery information, and check the system status via the touch screen.

7.1 Switch Language

Tap the  icon in the upper right corner of the screen to change the display language to English, Chinese, Arabic or French.

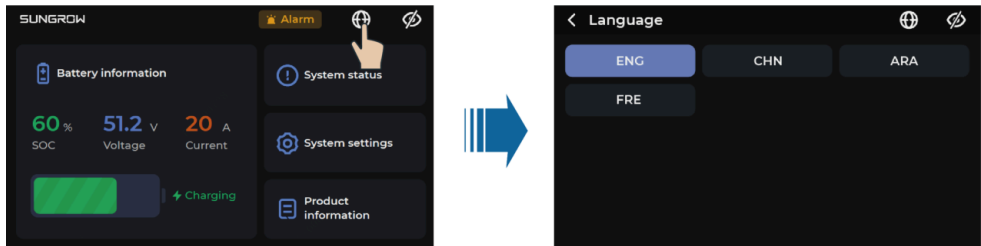

7.2 Viewing Battery Information

Tap **Battery information** on the left side of the screen to enter the battery information page and view the battery SOC, Voltage, etc.

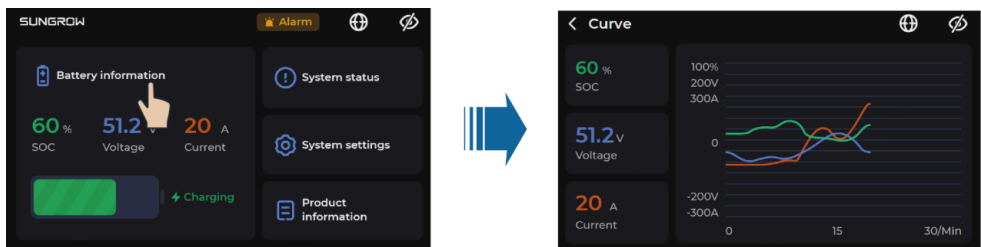

7.3 Viewing System Status

Tap **System status** on the right side of the screen to view the battery system status, **Protection status**, **Alarm status**, and **Fault status**.

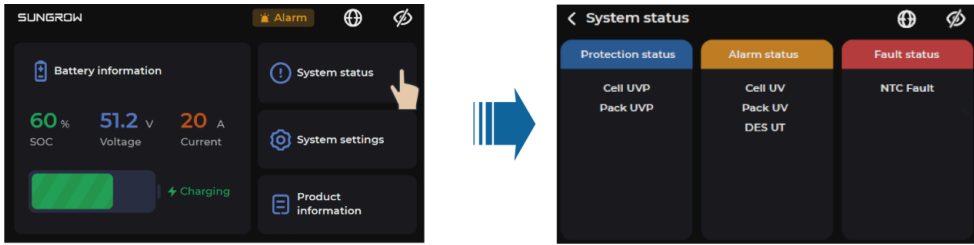

7.4 Battery System Settings

Tap **System settings** on the right side of the screen and enter the password to access system settings.

NOTICE

System settings are for after-sales only and generally require no customer operation. Please contact SUNGROW for the password to make adjustments.

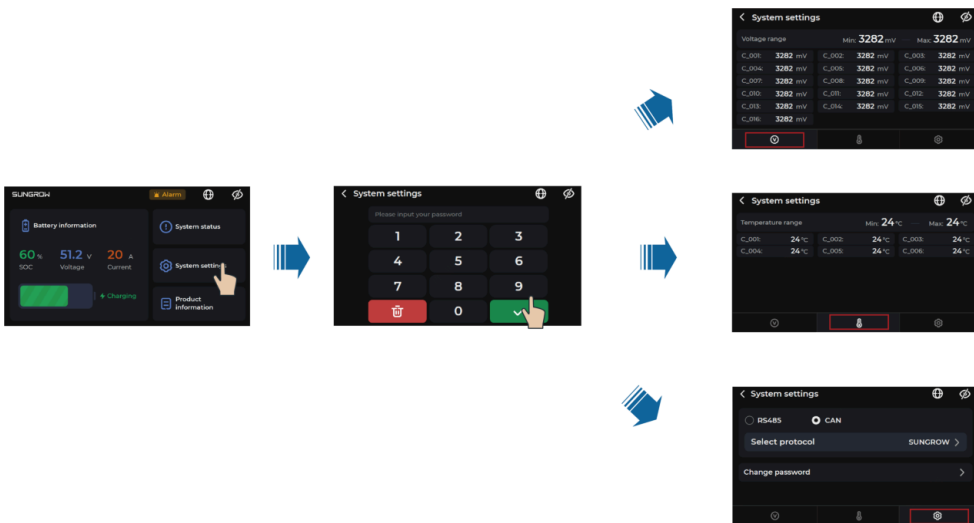

7.5 Viewing Product Information

Tap **Product information** on the right side of the screen to view the **Software version**, **S/N**, and **Manufacturer** of the battery.

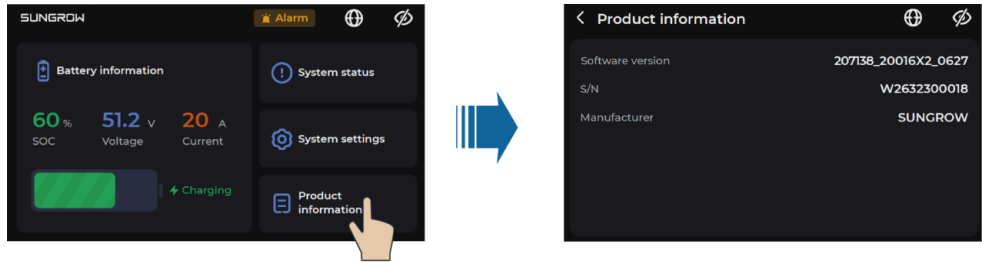

8 Battery Augmentation

If adding new batteries or replacing old/damaged batteries in the existing battery system, ensure that the new batteries meet the multi-battery cascading requirements before connection:

1. A maximum of 20 batteries can be connected in parallel.
2. It is recommended to select multiple batteries from the same batch for parallel wiring.
3. When multiple batteries are connected in parallel, terminal blocks are required. Please ensure that
 - The length of the power cable connecting each battery to the terminal block is consistent.
 - The wiring terminal block used must meet the charge and discharge current requirements when multiple batteries are connected in parallel.
4. Consistent battery status: Before connecting batteries in parallel, ensure that they have the same SOC and model, and the voltage difference between them is less than 1 V. If the battery SOC's are found to be inconsistent on site, handle it in any of the following ways:
 - First, connect one battery to the inverter to charge or discharge it until its SOC matches the other battery, and then perform parallel wiring.
 - Charge the batteries to the same SOC in the warehouse in advance, and then transport them to the site for installation.

9 Battery Decommissioning

Prerequisite

The battery in the system should be decommissioned once the hybrid inverter is out of service. Proceed with the following steps to decommission the battery.

Step 1 Switch the battery-side circuit breaker to OFF.

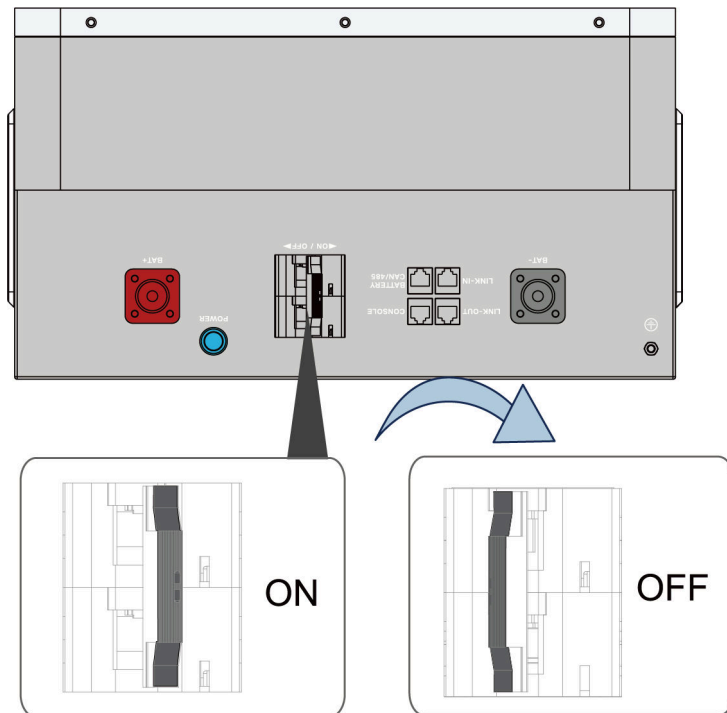

Step 2 Press and hold the power button for 3 seconds to turn off the battery; the screen will go off.

NOTICE

When multiple batteries are connected in parallel, turn off the switch of master battery and disconnect the circuit breakers of all batteries.

Step 3 Wait for one minute and disconnect and remove the battery power cables and communication cable.

--End

Please contact SUNGROW for battery disposal.

10 Troubleshooting and Maintenance

10.1 Troubleshooting

When a battery malfunctions, a brief description of the fault will appear under the **Fault status** interface of the **System status** screen.

Fault abbreviations and the corresponding troubleshooting methods are listed in the table below.

Fault Abbreviation	Fault Full Name	Solution
DSG OC	Discharge over-current alarm	Reduce the load power. No action is required. The fault is automatically cleared when the discharge current decreases.
DSG OCP	Discharge over-current protection	Reduce the load power. The battery automatically recovers from the first two over-current protections. If the discharge over-current protection is triggered 3 consecutive times, the output is kept disabled. Press the battery low-voltage control switch to restart the battery and clear the fault.
CHG OC	Charging over-current alarm	Reduce the charging power. No action is required. The fault is automatically cleared when the charge current decreases.
CHG OCP	Charging over-current protection	Reduce the charging power. The battery automatically recovers from the first two over-current protections. If the charging over-current protection is triggered 3 consecutive times, the charging MOS is kept disabled. Discharge or press the battery low-voltage switch to restart the battery and clear the fault.
DSG OCP 2	Discharge over-current protection 2	Reduce the load power. The battery automatically recovers from the first two over-current protections. If the discharge over-current protection is triggered 3 consecutive times, the output is kept disabled. Press the battery low-

Fault Abbreviation	Fault Full Name	Solution
		voltage control switch to restart the battery and clear the fault.
CHG OT	Charging over-temperature alarm	No action is required. Reduce the charging power. The alarm clears automatically when the temperature drops below 50°C. It is usually triggered when operating without communication. In the communication status, the battery requests current derating according to different temperature points.
CHG OTP	Charging over-temperature protection	No action is required. Over-temperature protection triggers at 55°C to reduce charging power. The fault is automatically cleared when the temperature drops below 50°C. It is usually triggered when operating without communication. In the communication status, the battery requests current derating according to different temperature points.
CHG UT	Charging under-temperature alarm	No action is required. The fault is automatically cleared when the temperature rises above 2°C. Choose a product with a heating function or move the product to a high-temperature environment.
CHG UTP	Charging under-temperature protection	No action is required. Protection is triggered when the temperature is not higher than 0°C, and automatically cleared when the temperature rises above 2°C. Choose a product with a heating function or move the product to a high-temperature environment
DSG OT	Discharge over-temperature alarm	No action is required. Reduce the discharge power. The fault is automatically cleared when the temperature drops below 55°C. It is usually triggered when operating without communication. In the communication status, the battery requests current derating according to different temperature points.
DSG OTP	Discharge over-temperature protection	No action is required. Reduce the discharge power. Protection is triggered when the maximum cell temperature rises above 60°C.

Fault Abbreviation	Fault Full Name	Solution
		The fault is automatically cleared when the temperature drops below 55°C. It is usually triggered when operating without communication. In the communication status, the battery requests current derating according to different temperature points.
DSG UT	Discharge under-temperature alarm	No action is required. The fault is automatically cleared when the minimum cell temperature rises above -15°C. Choose a product with a heating function or move the product to a high-temperature environment.
DSG UTP	Discharge under-temperature protection	No action is required. Protection is triggered when the minimum cell temperature is not higher than -20°C. It is automatically cleared when the temperature rises above -15°C. Choose a product with a heating function or move the product to a high-temperature environment.
ENV OT	Environment over-temperature alarm	The environment over-temperature alarm is triggered when the environmental temperature rises above 65°C. Move the product to an environment with lower temperatures. The fault is automatically cleared when the temperature drops below 65°C.
ENV OTP	Environment over-temperature protection	The environment over-temperature protection is triggered when the environmental temperature exceeds 70°C. Move the product to an environment with lower temperatures. The fault is automatically cleared when the temperature drops below 65°C.
ENV UT	Environment under-temperature alarm	No action is required. It is automatically cleared when the environmental temperature rises above -15°C. Choose a product with a heating function or move the product to a high-temperature environment.
DSG UTP	Environment under-	No action is required. Protection is triggered when the environmental temperature is not higher than -20°C. The fault is automatically

Fault Abbreviation	Fault Full Name	Solution
	temperature protection	cleared when the temperature rises above -15°C. Choose a product with a heating function or move the product to a high-temperature environment.
MOS OT	MOS over-temperature alarm	An MOS over-temperature alarm is triggered when the MOS temperature rises above 90°C. Reduce the load or charging power. The fault is automatically cleared when the temperature drops below 90°C.
MOS OTP	MOS over-temperature protection	MOS over-temperature protection is triggered when the MOS temperature exceeds 95°C. Reduce the load or charging power. It is automatically cleared when the temperature drops below 85°C.
CELL OV	Cell overvoltage alarm	A cell overvoltage alarm is triggered when the maximum cell voltage is not lower than 3.6 V. The fault is automatically cleared when the voltage drops below 3.6 V. This usually occurs only during charging without communication. This fault is cleared immediately after a discharge.
CELL OVP	Cell overvoltage protection	Cell overvoltage protection is triggered when the maximum cell voltage is not lower than 3.65 V. The fault is automatically cleared when the voltage drops below 3.4 V. This usually occurs only during charging without communication. This fault is cleared immediately after a discharge.
CELL UV	Cell undervoltage alarm	A cell undervoltage alarm is triggered when the minimum cell voltage is less than 2.9 V. The fault is automatically cleared when the minimum cell voltage during charging is greater than 2.9 V.
CELL UVP	Cell undervoltage protection	Cell undervoltage protection is triggered when the minimum cell voltage is less than 2.8 V. The fault is automatically cleared when the minimum cell voltage during charging is greater than 3 V.

Fault Abbreviation	Fault Full Name	Solution
PACK OV	Pack overvoltage alarm	A pack overvoltage alarm is triggered when the pack voltage is not lower than 57.6 V. The fault is automatically cleared when the voltage drops below 57.6 V. This usually occurs only during charging without communication. This fault is cleared immediately after a discharge.
PACK OVP	Pack overvoltage protection	Pack overvoltage protection is triggered when the pack voltage is not lower than 57.6 V. The fault is automatically cleared when the voltage drops below 54.4 V. This usually occurs only during charging without communication. This fault is cleared immediately after a discharge.
PACK UV	Pack undervoltage alarm	A pack undervoltage alarm is triggered when the pack voltage drops below 46.4 V. The fault is automatically cleared when the pack charging voltage rises above 46.4 V.
PACK UVP	Pack undervoltage protection	Pack undervoltage protection is triggered when the pack voltage drops below 44.8 V. The fault is automatically cleared when the pack charging voltage rises above 48 V.
CELL Fault	Cell sampling fault	Equalize cells with large voltage differences, upgrade the program, or check the voltage sampling line.
SCD	Short circuit protection / discharge hardware fault	For short circuit protection, press the low-voltage control switch to restart. For discharge hardware protection, replace the BMS or upgrade the program.

10.2 Maintenance

The recommended maintenance intervals for batteries are listed as follows, which however should be adjusted according to the actual installation environment.

The maintenance interval of the product is subject to factors such as power plant size, location, and site conditions.

Inspection Item	Inspection Method	Maintenance Interval
Battery cleanliness	<ul style="list-style-type: none"> • Check the battery appearance for damage or deformation. • Check if the humidity and the amount of dust inside the PACK are in the normal range. Clean the PACK if necessary. 	Every 6 to 12 months
Battery operating status	<ul style="list-style-type: none"> • Check if the internal components make abnormal noises while running. • Check if the temperature inside the RACK goes too high. • Check that the battery parameters are set correctly when the battery is in operation. 	Every 6 months
Warning signs	Check if warning labels and signs are legible and clean. Clean it if necessary.	Every 6 months
Cables	<ul style="list-style-type: none"> • Check if the switch gear is correctly connected to the hybrid inverter. • Check if the cables are intact and free of scratches. 	Every 6 months
Corrosion	Check if the PACK has oxidized or rusted inside.	Once every 6 months
Grounding reliability	Check whether the PE cables are firmly connected.	Initial inspection should be performed 6 months after commissioning. Thereafter, the inspection interval is 6 to 12 months.

10.3 Charging Requirements After Battery Over-discharge

A battery with a 90% depth of discharge is in an over-discharged state. Store the over-discharged battery according to the following requirements; otherwise, the battery will be damaged.

Storage Ambient Temperature	Storage Time	Notice
-10~25°C	≤ 15 days	Disconnect the battery pack from the inverter to prevent trickle discharge.
25 to 35°C	≤ 7 days	
35~45°C	≤ 12 hours	Connect the battery pack to the inverter.

NOTICE

If the battery is not stored according to the above storage conditions, the resulting battery damage is not covered by the warranty.

11 Appendix

11.1 Technical Data

Technical properties	MBL050	MBL120	MBL160
System Data			
Battery type	LiFePO4		
Nominal energy	5.12 kWh	11.8 kWh	16.08 kWh
Battery cycles ⁽¹⁾	6000	6000	8000
Nominal voltage	51.2 V		
Voltage range	44.8 V to 57.6 V		
Nominal charging / discharging current	50 A / 50 A	115 A / 115 A	157 A / 157 A
Max. charging / discharging current	100 A / 100 A	230 A / 230 A	200 A / 200 A
Peak charging(1s) / discharging current(3s)	110 A / 150 A	250 A / 300 A	210 A / 300 A
Min. discharging current	2 A		
Communication			
Display	LCD touchscreen		
Language	Chinese, English, Arabic, French		
Display Parameters	SOC, Pack voltage, Pack current, Charging / Discharging status,		
Communication interface	CAN / RS485		

Technical properties	MBL050	MBL120	MBL160
Protection			
Over / under voltage protection		Yes	
Over current protection		Yes	
Over / under temperature protection		Yes	
DC breaker		Yes	
General Data			
Dimensions (W*H*D)	494 mm * 513 mm * 155 mm	432 mm * 715 mm * 243 mm	432 mm * 855 mm * 243 mm
Weight	47.5 kg	86.5 kg	114.2 kg
Degree of protection		IP20	
Mounting method *	Floor-mounted (Built-in casters) or Wall-mounted		
Installation location	Indoor		
Operating ambient temperature range	Charge □ 0 to 55 °C (32 °F to 131 °F) Discharge □ -20 to 55 °C (-4 °F to 131 °F)		
Allowable relative humidity range	5% to 95% (non-condensing)		
Storage condition	6 month @25°C; 3 month @35°C; 1 month @45°C		
Max. operating altitude	2000 m		
Cooling method	Natural convection		
Max. parallel units	20		
Certification	CE, IEC 62619, IEC 62477, UN 38.3, MSDS, RoHS		

Technical properties	MBL050	MBL120	MBL160
Compatible inverters		MG5 / 6 / 8 / 10 / 12RL	

(1): Life cycle test conditions: 90% DOD, 0.5C charge & discharge at 25°C.

(2): Wall mounting only for MBL050. MBL120 and MBL160 require additional wall mounting accessories.

11.2 Quality Assurance

When any product fault occurs during the warranty period, Sungrow Power Supply Co., Ltd. (hereinafter referred to as the Company) will maintain or replace the product for free.

The software security update period for this product is consistent with the product warranty period. During the warranty period, if security vulnerabilities or compatibility issues are found, corresponding software patches or security updates will be provided.

Evidence

During the Company's warranty period, the customer shall provide the product purchase invoice and date. Meanwhile the trademark should be clearly legible. Otherwise Company has the right to exclude liability claims. Refer to the warranty document for the warranty period and conditions.

Conditions

- After replacement, unqualified products shall be processed by the Company.
- The customer shall give the Company a reasonable period to repair the faulty equipment.

Exclusion of Liability

In the following circumstances, the Company has the right to refuse to honor the quality guarantee:

- The free warranty periods for the whole machine/components have expired;
- The device is damaged during transportation;
- The device was incorrectly installed, refitted, or used;
- The device operates under harsh conditions beyond those described in this document;
- The fault or damage was caused by installation, repairs, modification, or disassembly performed by a service provider or personnel other than SUNGROW;
- The fault or damage was caused by the use of non-standard or non-SUNGROW components or software;

- The installation and use range is beyond the stipulations of the relevant international standards;
- The device is damaged by an abnormal natural environment.

If a product fault arises due to any of the above causes and the customer requires repair services, such service may be provided for payment, following the judgment of this company's service institution.

If the size and parameters of the product are changed, the latest information of the Company will prevail without notice.

11.3 Contact Information

In case of questions about this product, please contact us. We need the following information to provide you the best assistance:

- Model of the device
- Serial number of the device
- Fault code/name
- Brief description of the problem

For detailed contact information, please visit: <https://www.sungrowpower.com/en/about-us/contact-us>

Sungrow Power Supply Co., Ltd.

www.sungrowpower.com